

## Design and Implementation of a PLC based Electricity Supply Switching Control System

B.I.Aldi<sup>1</sup>, J.S.Kadadevarmath<sup>2</sup>, N.P.Bannibagi<sup>3</sup>

<sup>1,2</sup>(Department of Physics/Electronics, Karnatak University, Dharwad, Karnataka, India)

<sup>3</sup>(Advanced Training Institute for Electronics and Process Instrumentation, Hyderabad, Telangana, India)

**Abstract:** Electricity switching control systems are basically used for supplying energy efficiently to a given load in building automation applications. The integration of mains power supply with solar power supply and diesel generator power supply is a key element in designing the electricity supply switching control system. This paper presents a real time prototype design and implementation of automatic control system for mains electricity power distribution to the load using Programmable Logic Controller (PLC) - Allen Bradley MicroLogix 1100, 1763-L1BBB. PLC is programmed using ladder diagram for intelligent switching of both solar power supply and diesel generator power supply units. Further, it is so programmed that solar power supply energy usage to the output power load exists, till the diesel generator power supply approaches to stable output. The Rockwell Software Logix 500 is used for programming a PLC, running on a host computer terminal. For completeness, the control program results are compared with a hardware interfacing module.

**Keywords:** DGS, LD, MPS, PLC, SPS

### I. Introduction

An automatic control system is the technology to control and process a large amount of data in a very short time. The programmable logic controller (PLC) is a light-weight, low-cost and self-contained electronic apparatus for a wide range of industrial automation applications. This is widely used to control a simple, repetitive task and connected to multiple PLCs or to a host computer in order to integrate the control of a complex process. The controller actions in different modes can be monitored with the use of personal computer (PC). A typical PLC consists of a power supply, processor, input/output (I/O) modules and specialized modules

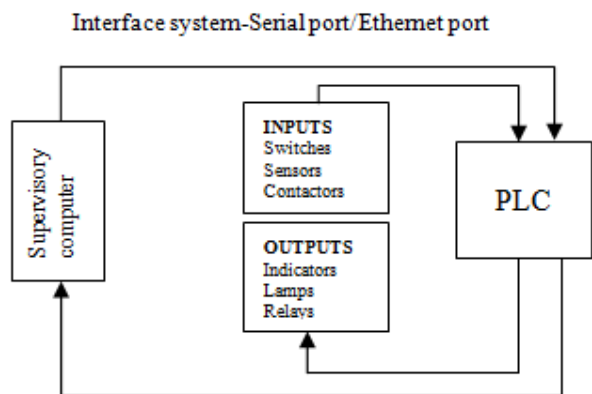

**Fig. 1:** Control System Based On PLC

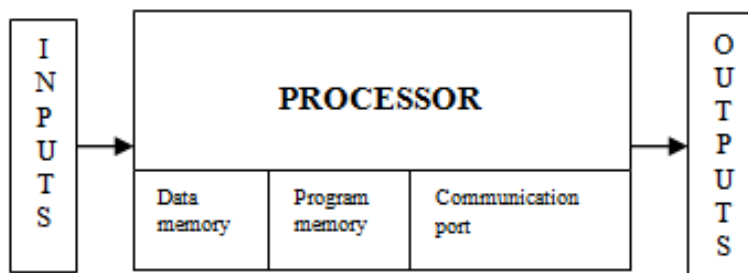

**Fig. 2:** Block Diagram of PLC

[1], [2]. Fig.1 shows the control system based on PLC, consists of supervisory computer, electronic field instruments and other electro-mechanical devices such as switches, sensors and contactors at the input module and indicators, lamps, relays, control valves etc., at the output modules. Now a day the buildings are incorporated with more electrical appliances and electronic systems, which in turn require more controls. PLC allows the user to combine its input / output (I/O) modules to form control system, as shown in Fig.2 of the basic block diagram of PLC. In this system, control program for the specific application is stored in the memory. This program is then executed as a part of the cycle of internal operations of the PLC. The PLC is continuously scans memory to achieve control over the operation of the machine or process. Thus the controller repeatedly performs three steps: reads inputs from input modules, solves preprogrammed control logic and generates outputs to output module based on the control logic solutions. The automatic operation programmed in the PLC is triggered by an operator on the supervisory computer [3], [4]. At the same time information of the programs can be recorded and monitored by the Supervisory Control and Data Acquisition (SCADA) software.

The programming of PLC is performed by using a Ladder Diagram (LD) / ladder logic program (LLP). This is graphical programming language uses software to emulate the hardwired devices of the relay ladder logic [5] - [8]. The programmed operations work on a straightforward two-state ON or OFF basis and these alternate possibilities correspond to LOW OR HIGH (logical form) and 0 or 1 (binary form). The basic techniques involved in developing LD programs is to represent basic switching operations, involving digital logic operations of AND, OR, Exclusive OR, NAND, NOR, and latching [9]. Thus the program written by this method uses Boolean algebra needed to design and analyze the program. Boolean logic and truth table can be represented with Boolean equations and can be simplified to develop LD program [10]. PLCs provide many advantages over conventional relay type of control, including increased reliability, more flexibility, lower cost, communication capability, faster response time and convenience to troubleshoot [11]. They remove pulsing effect of switching operations, replace mechanical relays, specially developed and relatively simple ladder diagram programming language makes the electrician and technicians to develop and control program without any difficulty, use built in opto couplers for driving input and output interface devices. It is possible to design easily and modify the control program without any changes in the hardware connections to the input and output devices. This paper presents one of the building automation applications of PLC in monitoring and controlling of uninterrupted electricity to the load during mains supply failure by considering the solar power supply and diesel generator power supply as the alternative standby energy sources, and is arranged as follows. Section 2 describes the electricity supply switching control system design for the controller. This includes software development (algorithm, flow chart and LD programming) of PLC. Section 3 discusses the hardware module implementation, section 4 covers results and discussions obtained by interface module and the final section 5 contains conclusions.

## II. Design Of Electricity Switching Control System

The proposed design and implementation of intelligent electricity supply switching control for building automation involves both hardware and software components. The hardware components include PLC as a controller, input and output hardware interface modules. Allen Bradley MicroLogix 1100, 1763-L1BBB PLC [12] is used as programmable controller which uses Rockwell Software (RS) Logix 500 as control logic software, running on the host computer terminal. The development of software program and its implementation using PLC is as follows

### 2.1 Software Development

The PLC embedded software system is different from conventional computer programming software. It deals with control signals for interaction of physical environments rather than data computation. The development of the intelligent electricity supply switching control program is based on the logic conditions given in the Truth Table 1. In this table, Mains Power Supply input (MPS I/P) and Diesel Generator Supply input (DGS I/P) are considered as two input variables to the PLC and the four output variables are MPS, Solar Power Supply (SPS), DGS and DGS Starter (DGSS). The logic condition 0 is considered as OFF state and the logic condition 1 is considered as ON state of the variables. It is required to set the Output Power to the Load (OPL) to be in ON state by the output variables and is based on the automatic switching conditions of the desired input variables.

**Table 1:** Truth Table For Electricity Supply Switching Control

Input variables		Output variables				OPL
MPS I/P (I/0)	DGS I/P (I/1)	MPS (O/0)	SPS (O/1)	DGS (O/2)	DGSS (O/3)	
0	0	0	1	0	1 (3s)	1
0	1	0	0	1	0	1
1	1	1	0	0	0	1
1	0	1	0	0	0	1

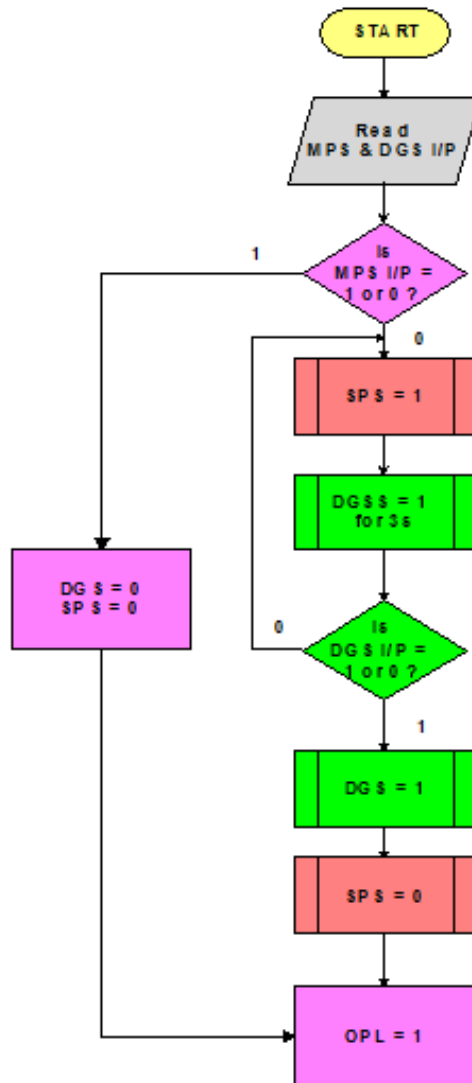

Fig. 3: Flow Chart of Control Program



Fig 4: PLC to PC Communication

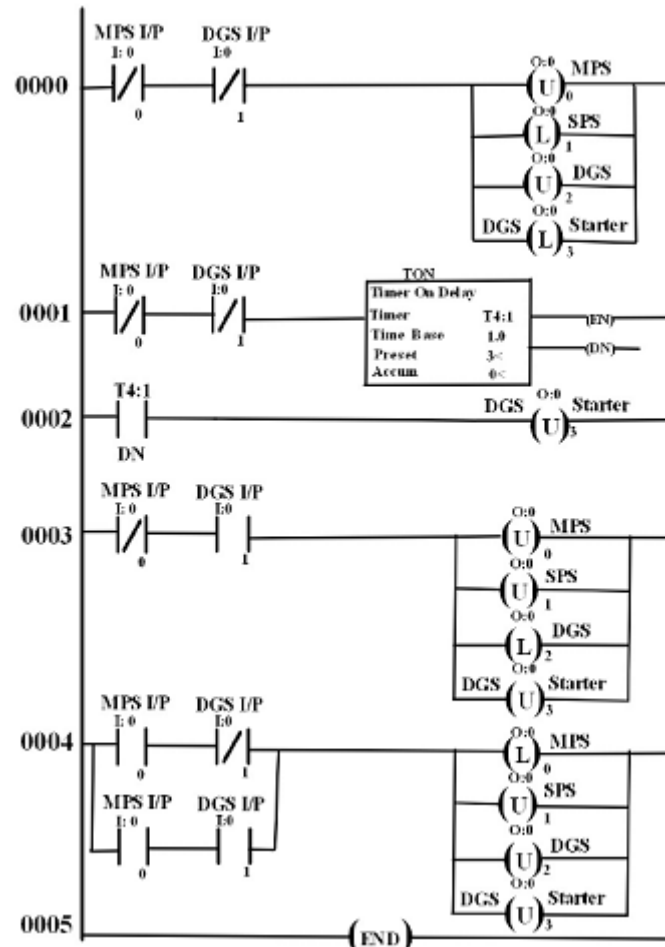

Fig. 5: LD Program for Electricity Switching Control

**2.1.1 Algorithm**

The MPS I/P and DGS I/P are labeled as Input I/0 and Input I/1 respectively. The four Outputs MPS, SPS, DGS and DGSS are labeled as Output O/0, Output O/1, Output O/2 and Output O/3 respectively. The algorithm steps involved for switching the OPL in the ON state can be summarized as follows.

**STEP 1:** I/0 = 0 and I/1 = 0

In this step, MPS I/P and DGS I/P both are OFF. To keep the OPL in the ON state, SPS (O/1) becomes ON. At the same instant, ON time of 3s is assigned for DGSS to trigger the DGS switch to be start.

**STEP 2:** I/0 = 0 and I/1 = 1

MPS I/P OFF and DGS I/P is ON, as it is previously stated in step 1 that DGS switches to ON due to the trigger pulse from the DGSS start. Thus, as the DGS I/P switch to ON state, DGS (O/2) supply energy to the OPL and at the same instant SPS (O/1) switches to OFF state.

**STEP 3:** I/0 = 1 and I/1 = 1

At this step, the MPS I/P switch to ON state. Due to this DGS (O/2) switches to OFF state and the output variable MPS (O/0) switch ON to supply energy to the OPL.

**STEP 4:** I/0 = 1 and I/1 = 0

The last step of the table shows that, as the MPS I/P in the ON state, and then the DGS I/P set to OFF state. MPS (O/0) is still in the previous state to supply energy to the OPL.

The above steps are repeated to keep the OPL in constantly ON state by the output variables during mains failure.

**2.1.2 Flow Chart**

The flow chart can be written before programming and is shown in Fig.3. At the beginning, all the input and output variables are to be read by the control program. The OFF states are indicated by 0 and ON

states are indicated by 1. During the failure of MPS I/P, in order to keep OPL uninterrupted, immediate switching ON of SPS is to be activated. At the same time DGSS switches to ON state for a delay of 3s to activate the DGS I/P. When the DGS is activated, the control output switches OFF the SPS and supply energy of the DGS to the OPL. If the main power restored back, MPS I/P switch ON, then the OPL maintains ON. The DGS supply input can be now switched OFF. The control flow diagram repeats and maintains the uninterrupted electricity to the OPL during the mains failure.

### 2.1.3 Programming

The programming is done by connecting the PLC and PC as shown in Fig.4. PLC is powered with the DC voltage of 24V and is communicated with PC through the port RS-232. The software tool Rockwell Software (RS) Linx Classic is used for configuration of serial port [13]. The RS Logix 500 LD software supports programming on windows operating system. LD program uses graphical symbols for logic conditions in each instruction. The program emulates the flow of electric current through a series of input conditions and enables output conditions. The instructions were executed rung by rung [14], [15]. Fig. 5 shows the LD program tested in the PC for automatic electricity supply switching control application. This has six rungs from 0000 to 0005. These rungs are developed based on the logic conditions of the algorithm, truth table and flow chart. The input variables used are the MPS I/P and DGS I/P. These are assigned to examine if open (XIO) / examine if close (XIC) instructions. The bit addresses used are I: 0/0 and I: 0/1. Here 'I' stands for input, '0' stands for 0<sup>th</sup> word and the last digits '0' and '1' indicates the bit addresses of the corresponding input variables. The output variables MPS, SPS, DGS and DGS Starter are assigned to the Output Latch (OTL) and Output Unlatch (OTU) instruction bit addresses. These are retentive output instructions and the bit addresses used for output variables MPS, SPS, DGS and DGS Starter are O: 0/0, O: 0/1, O: 0/2 and O: 0/3 respectively. The term 'O' indicates output, '0' indicates the 0<sup>th</sup> word of the output address and '0 to /3' are the bit addresses of the output variables. The sequence of operation of each rung is given in the next section.

#### 2.1.3.1 Sequence of Operations of Rungs

**Rung 0000:** In this rung the input variables MPS I/P and DGS I/P are set to OFF. Then the address bits O: 0/1 and O: 0/3 assigned to the OTL instructions, which correspond to the address of output variables SPS and DGS Starter are energized. Thus the bit is set (turned on or enabled).

**Rung 0001:** Here input variables MPS I/P and DGS I/P are in the previous rung states and the 3s ON time delay is used to switch ON the DG starter push button by the ON time timer instruction addressed as T4:1. The preset value of is set to 3s and accumulator value is set to 0 in the timer.

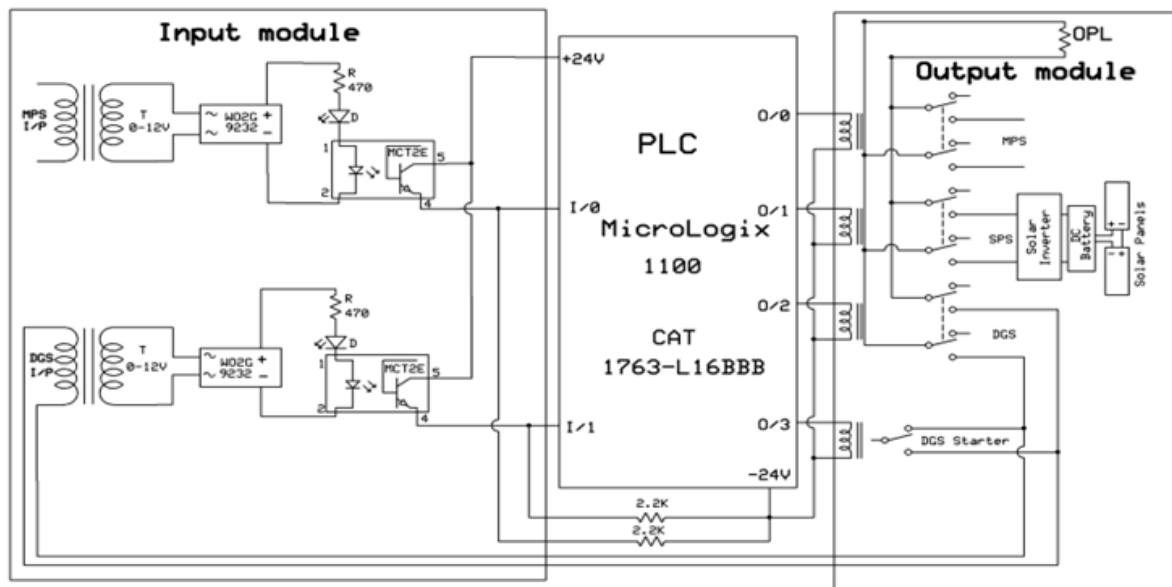

Fig. 6: Hardware Interfacing To A PLC

**Rung 0002:** At the end of the ON time delay, that is when the pre-set value is equal to the accumulator count value of 3s of the T4:1 timer, the output of this timer is given to the OTU instruction of the address bit O:0/3 for unlatching or releasing the push button of the DG Starter.

**Rung 0003:** In this rung, the input variable MPS I/P assigned with the XIO instructions and DGS I/P is assigned with examine if closed XIC instruction. When the DGS I/P is forced ON by using this instruction, then

the bit address is evaluated as true/ON. Due to this the output OTL of address bit O: 0/2 enabled to switch ON the DGS and at the same time SPS unlatches due to instruction OTU of the address bit O: 0/1.

**Rung 0004:** As previously explained in the rung 0003 that the DGS is being switched ON due to enable of the input variable address I: 0/1 of the DGS I/P. During enabling of MPS I/P by the address bit I: 0/0 using XIC instruction, the output variable of the DGS address bit O: 0/2 unlatches and MPS address bit O: 0/0 latches to provide mains power to output power supply. Now the DGS I/P can be switched OFF by the XIO instruction of the address bit I: 0/1.

**Rung 0005:** The last rung shows end of the ladder logic program.

### III. Hardware Implementation

The hardware modules used for automatic switching control of electricity supply for building automation includes Allen Bradley MicroLogix 1100, 1763-L1BBB PLC integrated with input and output modules. Input and output hardware interface switching control modules are connected to the PLC for testing the control circuit and program is shown in Fig.6 . Experimental set up for the testing of electricity supply switching control I/O module interfaced to the PLC is shown in Fig.7.



**Fig. 7:** Testing Of I/O Modules

#### 3.1 Input Interface Module

The input interface module includes the Mains Power Supply input (MPS I/P) and Diesel Generator Supply input (DGS I/P) sources. These sources produce alternating current (AC) of 230 V, 50 Hz. The output module is controlled by sensing the presence or absence of these signals appearing at the input terminals of the PLC. The AC voltage of the sources is step-down to 12V by the transformers and is converted to direct current (DC) by the components WO2G 9232. This voltage is used by the opto couplers MCT2E to force ON the corresponding inputs of PLC by enabling its 24V DC power supply. MPS I/P, and DGS I/Ps are connected to the terminals I/0, and I/1 of the controller.

#### 3.2 Output Interface Module

The output module is interfaced to the output terminals O/0, O/1 and O/2 of the PLC through the control relay (CR) coils MISH224L. These are used for switching the MPS, SPS and DGS respectively to the output power load (OPL) during the mains power failure for providing uninterrupted supply. The terminal O/3 is connected to CR coil of MISH212L for switching the DG starter ON during mains failure along with SPS. The SPS uses 12V DC battery and is charged by the solar panels connected in series. The series connection adds voltage rating of panels and amperage (current) remains the same. The voltage stored in the battery is then converted to AC voltage of 230V by the solar inverter. 100W filament bulb is used at OPL for testing the control system. The components of the interfaced hardware module are provided with light emitting diodes (LEDs) to observe the real time status of the PLC. Also the same status indicates on the PLC's LCD display screen as well as on the LD program.

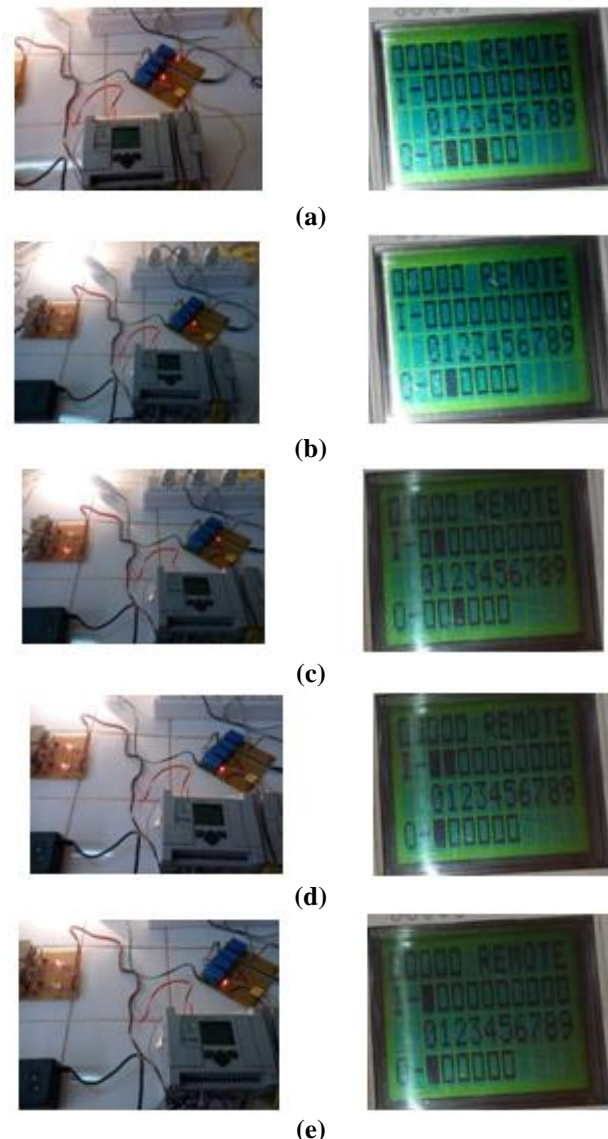

**Fig. 8:** Variations of input and output variables of electricity supply control. (a) Switching ON of SPS and DGSS during mains failure, (b) Switching OFF of DGSS after delay of 3s by keeping SPS intact, (c) Switching ON of DGS and switching OFF of SPS, (d) Switching OFF of DGS O/P during restore back of MPS, (e) Switching OFF of DGS I/P .

#### **IV. Results And Discussion**

The control system operates according to the design proposed for automatic electricity supply switching control. The observations are monitored for both inputs and outputs to the PLC along with the real time status of the hardware modules indicated by the LEDs are shown in Fig.8.

It is clear from the Fig. 8(a) that, during the failure of MPS input signal at I/0, at the same time both outputs SPS O/1 and DGS starter O/3 will switch ON as per control program. The SPS connects to load OPL and DGS starter switch ON the DGS. The starter switches ON for a time delay of 3s and then switches OFF as shown in Fig. 8 (b). Thus the starter of DGS acts as a push to ON button to turn ON the diesel generator. After switching ON of the DGS output O/2, SPS switches to OFF, as shown in Fig.8(c). If MPS input restored back as shown in Fig.8 (d), then MPS signal connects to OPL without any delay and DGS I/P switches to OFF as indicated in Fig.8 (e). During the change over period of the switch, bulb shows no variations in the intensity of illumination. This indicates that the switching speed is very high due to the use of PLC as a controller to provide uninterrupted power supply. That is the results observed on the LCD display screen of the controller based on our software design correlate well with real time prototype hardware interface modules. Thus it may be inferred that proposed model works satisfactorily.

## V. Conclusion

This paper presents a real time prototype design and implementation of automatic control system for mains electricity power distribution to the load using Programmable Logic Controller (PLC) - Allen Bradley MicroLogix 1100, 1763-L1BBB. PLC is programmed using ladder diagram for intelligent switching of both solar power supply and diesel generator power supply units. The proposed ladder logic control program works satisfactorily in accordance with the design considerations. It was found from the results of real time prototype hardware interfacing module that during switching control operations it provides uninterrupted electricity supply in building. Thus it may be inferred that the proposed model be considered in building automation applications.

## References

- [1]. Y. N Burali, PLC based industrial crane automation & monitoring. *Research inventory, International Journal of Engineering and Science*. 3(1), 2012, 1-4.
- [2]. T. Samanta, D.Sarkar, and S.Dasgupta, PC-PLC based vacuum control system for superconducting cyclotron at vecc. *10<sup>th</sup> ICALEPCS International Conference on Accelerator & Large Expt. Physics Control Systems*. Geneva, 2005, Oct 10-14,1-4.
- [3]. Ravikumar and S.K. Singal, Computer based control of operation and maintenance of SHP plants. *International Journal of Engineering Research and Technology*. 6(5), 2013, 651-658.
- [4]. K. Koo, G.S Rho, W.H Kwon, J. Park, and N. Chang, Architectural design of an RISC processor for programmable logic controllers. *Journal of Systems Architecture*. 44 (5), 1998, 311 - 325.
- [5]. A. Rullan, Programmable logic controllers versus personal computers for process control. *Computers & Industrial Engineering*. 33(1-2), 1997, 421-424.
- [6]. S.S. Peng, and M. C. Zhou, Ladder diagram and Petri- Net-based discrete-event control design methods. *IEEE transactions on Systems, Man, and Cybernetics - Part C (Applications and Reviews)*, 34(4), 2004, 523-531.
- [7]. G. Thiele, L. Renner, and R. Neimeier, Programmable logic controllers. *Control systems, Robotics and Automation*, ©Encyclopedia of Life Support Systems (EOLSS), Germany, 21.
- [8]. Rohner, and Peter. *PLC: Automation with programmable logic controllers; a textbook for engineers and technicians*. Kensington, N.S.W, UNSW Press, 1996.
- [9]. W. Bolton, Programmable logic controllers. Burlington, MA 01803, Elsevier Newnes,2006.
- [10]. H. Jack, Automating manufacturing systems with PLCs,2005.
- [11]. J. Rehg, PLC laboratories – the next generation. *ASEE Annual Conference & Exposition*. Montreal, 2002, June 16-19.
- [12]. Allen-/Bradley. MicroLogix 1100 programmable controller. *User Manual, Rockwell Automation, Bulletin 1763 controllers and 1762 Expansion I/O*. 1763-UM001C-EN-P, 2015.
- [13]. Allen-/Bradley. RSLinx® classic getting results guide. *Rockwell Automation, LINX-GR001O-EN-E*,2015.
- [14]. R. Wanga, X. Song, J. Zhu, and M. Gu, Formal modeling and synthesis of programmable logic controllers. *Journal of Computers in Industry*. 62, 2010, 23-31.
- [15]. Y. Birbir, and H.S. Nogay, Design and implementation of PLC-based monitoring control system for three-phase induction motors fed by PWM inverter. *International journal of systems applications, engineering & development*. 2(3), 2008, 128-135.